

R-Type[®] Enhanced Service Advantage Cartridge Secondary Belt Cleaner

Installation, Operation and Maintenance Manual

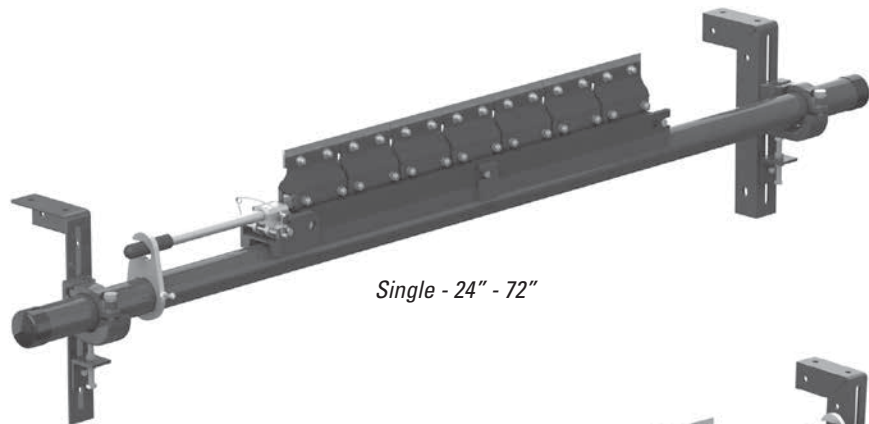

Single - 24" - 72"

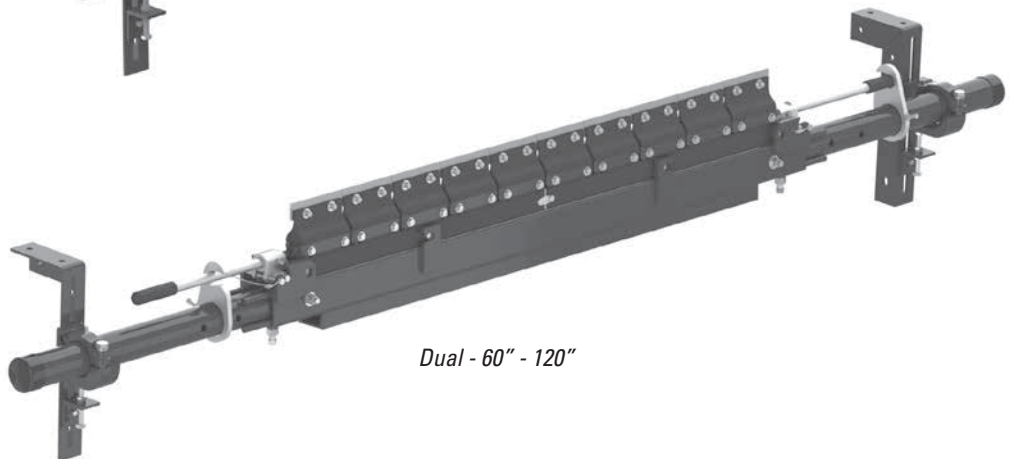

Dual - 60" - 120"

R-Type® ESAC Secondary Cleaner

Serial Number: _____
Purchase Date: _____
Purchased From: _____
Installation Date: _____

Serial number information can be found on the Serial Number Label included in the Information Packet found in the cleaner carton.

This information will be helpful for any future inquiries or questions about belt cleaner replacement parts, specifications or troubleshooting.

Table of Contents

Section 1 - Important Information	4
1.1 General Introduction	4
1.2 User Benefits	4
1.3 Service Option	4
Section 2 - Safety Considerations and Precautions	5
2.1 Stationary Conveyors.....	5
2.2 Operating Conveyors.....	5
Section 3 - Pre-Installation Checks and Options.....	6
3.1 Checklist.....	6
3.2 Optional Installation Accessories.....	7
Section 4 - Installation Instructions.....	8
4.1 Installation Instructions - R-Type ESAC Single Cartridge	8
4.2 Installation Instructions - R-Type E2SAC Dual Cartridge	12
4.3 Cartridge Replacement Instructions.....	16
Section 5 - Pre-Operation Checklist and Testing.....	20
5.1 Pre-Op Checklist.....	20
5.2 Test Run the Conveyor	20
Section 6 - Maintenance.....	21
6.1 New Installation Inspection.....	21
6.2 Routine Visual Inspection	21
6.3 Routine Physical Inspection	21
6.4 Maintenance Log.....	22
6.5 Cleaner Maintenance Checklist.....	23
Section 7 - Troubleshooting	24
Section 8 - Specs and CAD Drawing	25
8.1 Specs and Guidelines	25
8.2 CAD Drawing - R-Type ESAC (Single Cartridge) with C-Tips.....	26
8.3 CAD Drawing - R-Type ESAC (Single Cartridge) with V-Tips	27
8.4 CAD Drawing - R-Type E2SAC (Dual Cartridge) with C-Tips.....	28
8.5 CAD Drawing - R-Type E2SAC (Dual Cartridge) with V-Tips.....	29
Section 9 - Replacement Parts	30
9.1 Replacement Parts	30
Section 10 - Other Flexco Conveyor Products	31

Section 1 - Important Information

1.1 General Introduction

We at Flexco are very pleased that you have selected an R-Type ESAC Secondary Cleaner for your conveyor system.

This manual will help you to understand the operation of this product and assist you in making it work up to its maximum efficiency over its lifetime of service.

It is essential for safe and efficient operation that the information and guidelines presented be properly understood and implemented. This manual will provide safety precautions, installation instructions, maintenance procedures and troubleshooting tips.

If, however, you have any questions or problems that are not covered, please contact your field representative or our Customer Service Department:

Web site: Flexco.com

Customer Service: USA: 1-800-541-8028

Australia: 61-2-9680-3322 • **China:** 86-21-33528388

England: 44-1274-600-942 • **Germany:** 49-7428-9406-0

India: 91-44-4354-2091 • **Mexico:** 52-55-5674-5326

Singapore: 65-6281-7278 • **South Africa:** 27-11-608-4180

Please read this manual thoroughly and pass it on to any others who will be directly responsible for installation, operation and maintenance of this cleaner. While we have tried to make the installation and service tasks as easy and simple as possible, **it does however require correct installation and regular inspections and adjustments to maintain top working condition.**

1.2 User Benefits

Correct installation and regular maintenance will provide the following benefits for your operation:

- Reduced conveyor downtime
- Reduced man-hour labor
- Lower maintenance budget costs
- Increased service life for the belt cleaner and other conveyor components

1.3 Service Option

The R-Type ESAC Secondary Cleaner is designed to be easily installed and serviced by your on-site personnel. However, if you would prefer complete turn-key factory service, please contact your local Flexco Field Representative.

Section 2 - Safety Considerations and Precautions

Before installing and operating the R-Type ESAC Secondary Cleaner, it is important to review and understand the following safety information.

There are set-up, maintenance and operational activities involving both **stationary** and **operating** conveyors. Each case has a safety protocol.

2.1 Stationary Conveyors

The following activities are performed on stationary conveyors:

- Installation
- Blade replacement
- Repairs
- Tension adjustments
- Cleaning

DANGER

It is imperative that OSHA/MSHA Lockout/Tagout (LOTO) regulations, 9 CFR 1910.147, be followed before undertaking the preceding activities. Failure to use LOTO exposes workers to uncontrolled behavior of the belt cleaner caused by movement of the conveyor belt. Severe injury or death can result.

Before working:

- Lockout/Tagout the conveyor power source
- Disengage any takeups
- Clear the conveyor belt or clamp securely in place

WARNING

Use Personal Protective Equipment (PPE):

- Safety eyewear
- Hardhats
- Safety footwear

Close quarters, springs and heavy components create a worksite that compromises a worker's eyes, feet and skull.

PPE must be worn to control the foreseeable hazards associated with conveyor belt cleaners. Serious injuries can be avoided.

2.2 Operating Conveyors

There are two routine tasks that must be performed while the conveyor is running:

- Inspection of the cleaning performance
- Dynamic troubleshooting

DANGER

Every belt cleaner is an in-running nip hazard. Never touch or prod an operating cleaner. Cleaner hazards cause instantaneous amputation and entrapment.

WARNING

Belt cleaners can become projectile hazards. Stay as far from the cleaner as practical and use safety eyewear and headgear. Missiles can inflict serious injury.

WARNING

Never adjust anything on an operating cleaner. Unforseeable belt projections and tears can catch on cleaners and cause violent movements of the cleaner structure. Flailing hardware can cause serious injury or death.

Section 3 - Pre-installation Checks and Options

3.1 Checklist

- Check that the cleaner size is correct for the beltline width
- Check the belt cleaner carton and make sure all the parts are included
- Review the “Tools Needed” list on the top of the installation instructions
- Check the conveyor site:
 - Will the cleaner be installed on a chute
 - Is the install on an open head pulley requiring mounting structure (see 3.2 - Optional Installation Accessories)

Section 3 - Pre-installation Checks and Options

3.2 Optional Installation Accessories

Pole extenders are available for wide, non-standard conveyor structures.

76024

Pole Extender Kit

- Provides 30" (750mm) of extended pole length
- Includes 2 pole extenders

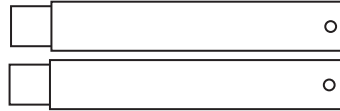

Optional Mounting Accessories

Description	Ordering Number	Item Code	Wt. Lbs.
Pole Extender Kit	MAPEK	76024	21.9

Lead time: 1 working day

Section 4.1 - Installation Instructions - Single Cartridge

R-Type® Enhanced Service Advantage Cartridge Secondary Belt Cleaner

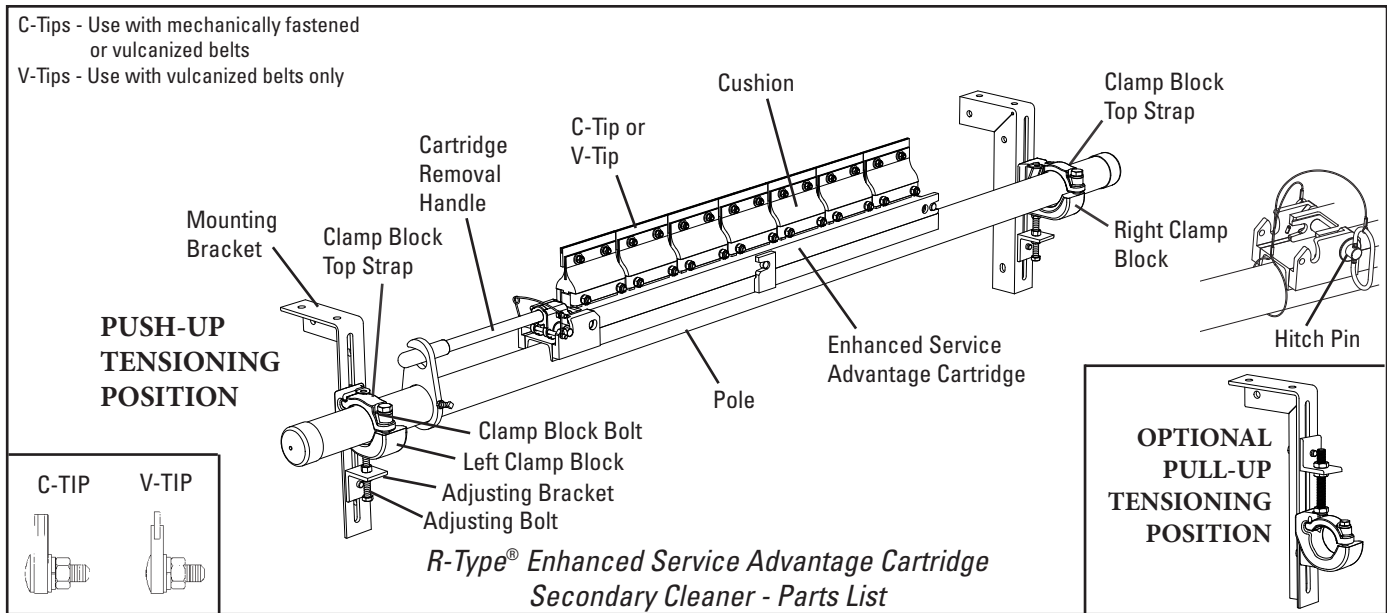

Physically lock out and tag the conveyor at the power source before you begin cleaner installation.

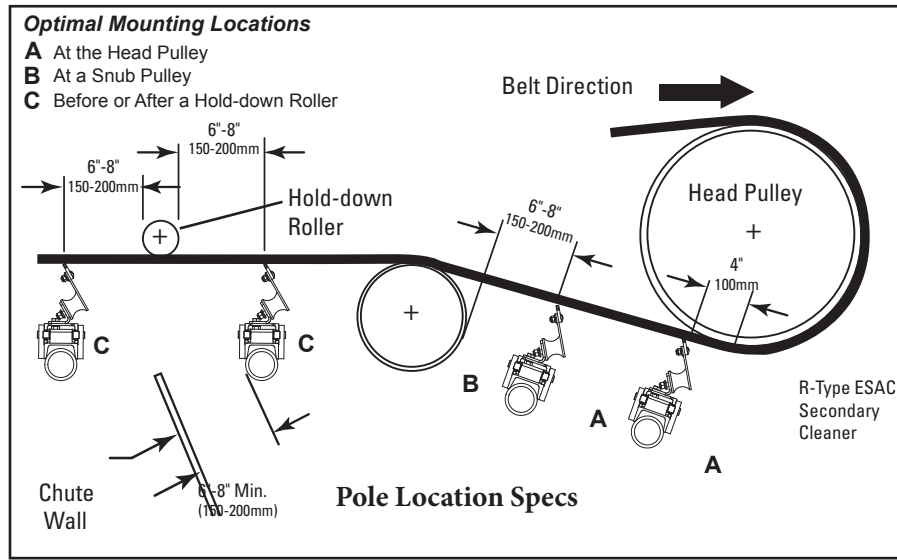

Clearance Requirements for Installation

Vertical	Horizontal
10-1/2" (267mm)	4-1/2" (114mm)

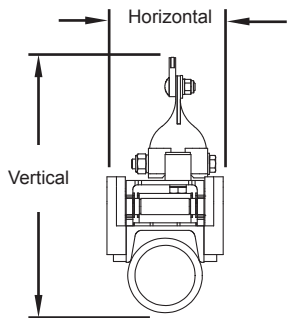

BEFORE YOU BEGIN:

- **PHYSICALLY LOCK OUT AND TAG THE CONVEYOR AT THE POWER SOURCE.**
- Double check the tip style needed for your application:
C-Tip - for mechanically spliced and vulcanized belts.
V-Tip - for vulcanized belts only.
- For chute mounting it may be necessary to cut an access hole to allow for installation and inspections. (See dimensions in STEP 2.)
- Follow all safety precautions when using a cutting torch.
- If welding, protect all fastener threads from weld spatter.
- For cleaner clearance requirements see chart above.

TOOLS NEEDED:

- TAPE MEASURE
- 3/4" (19mm) WRENCH
- Two 1/2" (13mm) WRENCHES
- RATCHET WITH 3/4" (19mm) SOCKET
- Two 6" C-CLAMPS (for temporary positioning of mounting brackets)
- CUTTING TORCH AND/OR WELDER
- MARKING PEN

Section 4.1 - Installation Instructions - Single Cartridge

1. Install mounting brackets. Determine the correct clamp block (left or right) and bracket needed for each side of the conveyor. The top strap should be offset away from the belt (you should be able to see the notch for the top strap from the outside of the conveyor (Fig. 1a).

For chute mounting: For a chute installation a belt location line must first be established. Draw a line on the chute replicating this location. If head pulley and snub pulley are close, it may be necessary to assume an approximate belt line between the two. In the determined location draw a line perpendicular to the belt line. Make a mark on this line 10" (254mm) below belt location line (Fig. 1b). Locate a mounting bracket along this line allowing the centerline of the clamp block to align with this 10" (254mm) mark (Fig. 1c). To move the clamp blocks, if necessary, loosen the clamp block lock bolts and the adjusting bracket lock bolt and move the clamp block to a position where the center of the hole is 10" (254mm) below the bottom of the belt. Bolt or weld mounting bracket in place. Repeat this step on the opposite side. On one side an access hole may be required (Fig. 1d). **NOTE:** The brackets must be aligned perpendicular to the belt.

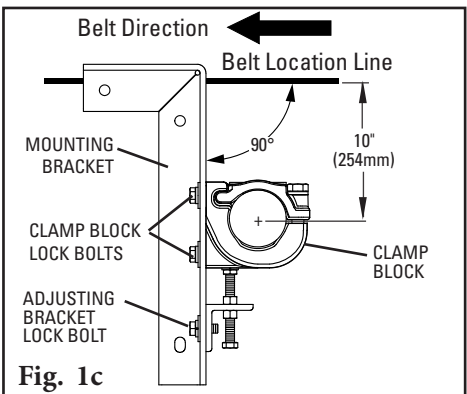
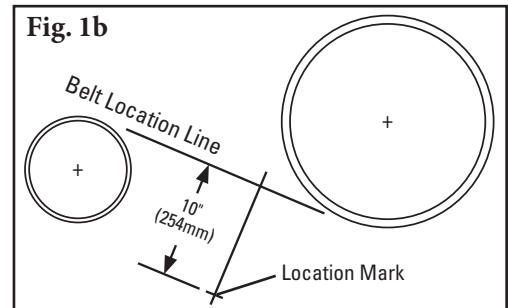
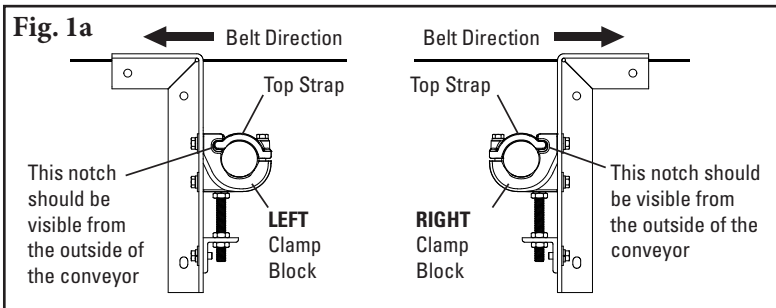

For structure mounting: In most applications the standard mounting brackets will have adequate room to fit on the structure with no cutting. Clamp the mounting bracket into position (use 6" clamps) to align the center of the block with a point 10" (254mm) below the belt (Fig. 1e). To move the clamp blocks, if necessary, loosen the clamp block lock bolts and the adjusting bracket lock bolt and move the clamp block to a position where the center of the hole is 10" (254mm) below the bottom of the belt. The bracket can now be bolted or welded in place. Locate and install bracket on the opposite side of belt in alignment with the first bracket. **NOTE:** The brackets must be aligned perpendicular to the belt.

2. Choose the tensioner position. The tensioner is shipped mounted in the push-up position. Depending upon the space constraints of the installation, the tensioner can be optionally mounted in a pull-up position. To do this, loosen the threaded rod lock nut, unscrew the threaded rod and remove adjusting bracket lock bolt. Then move the adjusting bracket and threaded rod to the top of the clamp blocks (Fig. 2) and tighten threaded rod lock nut.

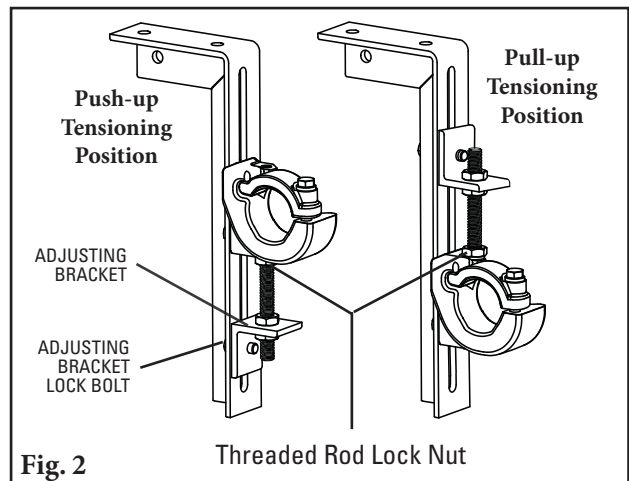
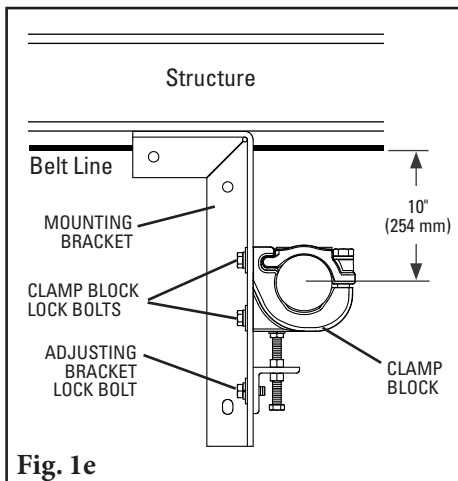
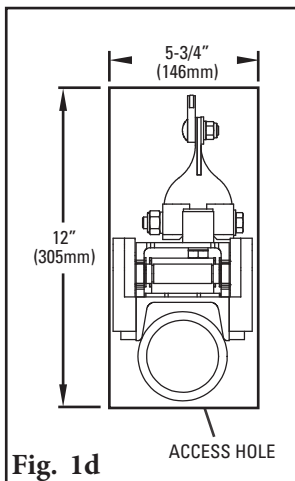

Section 4.1 - Installation Instructions - Single Cartridge

3. Install the pole.

Remove the cartridge from the pole. Remove the clamp block top strap on the access side of the conveyor, and on the opposite side, loosen the clamp block bolt enough to allow the pole to slide freely through (Fig. 3). Slide the pole across the belt, through the loosened clamp block on opposite side, and locate near end of pole into bottom section of clamp block. Replace the top strap over the pole and reinstall the clamp block bolt finger tight.

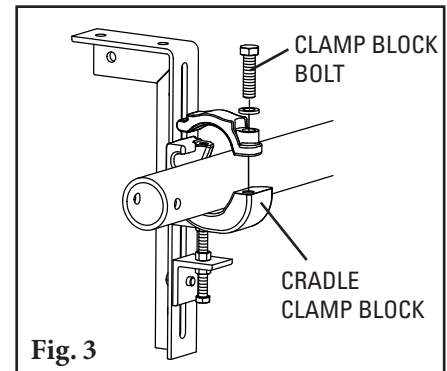

4. Different Cartridge Installation Methods.

Option A: Handle always on cartridge.

1. Slide the handle into the already installed knuckle, then tighten with supplied bolt/nut hardware.
2. Slide the cartridge onto the pole and lock down the knuckle onto the pole.
3. Slide the lock plate onto the pole, over the handle, then lock with the set screw.

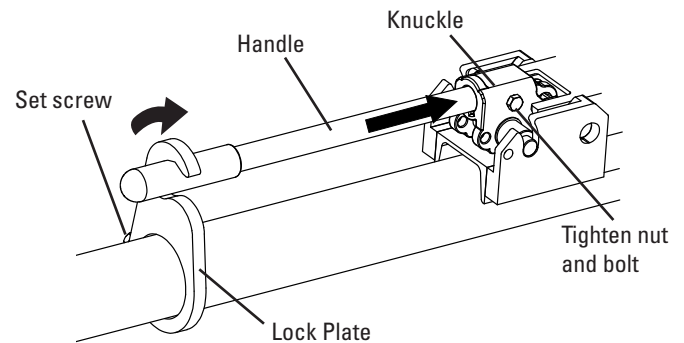

Option B: Handle stored inside pole.

1. Set the cartridge onto the pole, then slide the handle into the already installed knuckle.
2. Lock down the knuckle onto the pole, then remove handle and place into open pole end.
3. Using the lock pins provided, lock the knuckle and the handle in place.

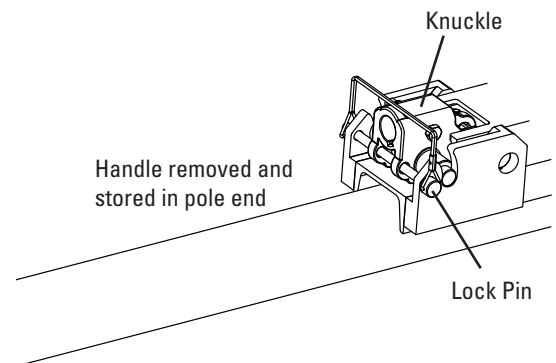

Option C: Hitch pin only.

1. To remove the knuckle assembly from the cartridge, flip cartridge upside down and use two 1/2" (13mm) wrenches to unlock knuckle pivot pins, then remove knuckle assy.
2. Set the cartridge onto the pole.
3. Use rubber mallet (to prevent damage to the cartridge) to lock into place.
4. Using the hitch pin provided, lock the cartridge in place.

Use 2 wrenches to loosen pivot pins, then remove knuckle assy

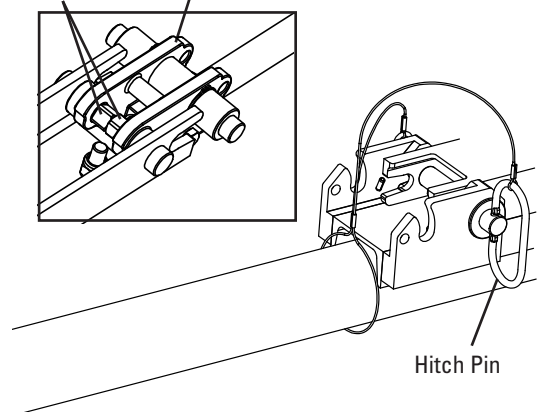

Section 4.1 - Installation Instructions - Single Cartridge

5. Set the tip angle.

Once the cartridge has been reinstalled, position the pole so the tips are centered on the belt and snug the clamp block bolt on both sides. Do not fully tighten.

6. Set the tip angle.

With angle gauge provided, rotate the tips to the preset angle (Fig. 6) and lock the pole in place by tightening the clamp block bolts.

NOTE: Make sure there is NO tip-to-belt contact while making this alignment. If contact occurs, lower the pole by loosening the clamp block lock bolts and raising the top adjusting bolt jam nut (Fig. 6). When the tips are not touching the belt, repeat this step.

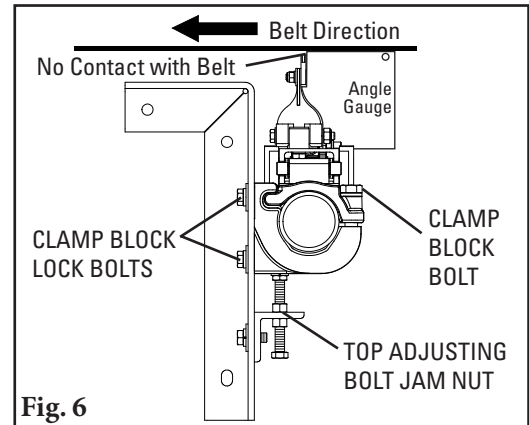

7. Set the tip tension.

With all clamp block lock bolts slightly loosened, back down the bottom adjusting bolt jam nut 4-5 turns on both sides (Fig. 7). Turn the top adjusting bolt jam nuts down until light contact is made between the tips and belt across the entire width of the cleaner. Give an additional 1 full turn to both top adjusting bolt jam nuts and tighten both bottom adjusting bolt jam nuts. Tighten all clamp block lock bolts. Double check that all bolts and nuts on the cleaner are tight.

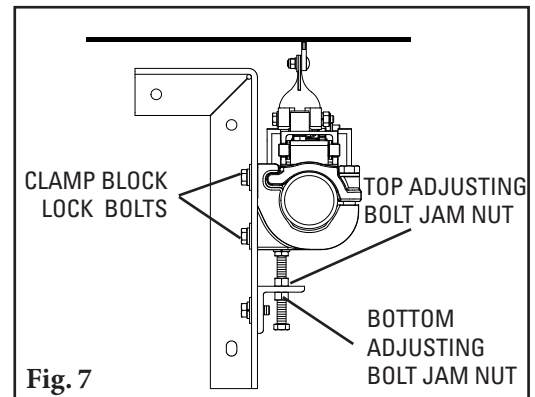

8. Check the tip tension.

Pull back on the outside tip until the tip-to-belt contact is broken and release. If the cleaner is correctly tensioned the complete blade of the adjacent tip will be visible (Fig. 8). If not, add (or reduce) tension by making 1/4 turn adjustments on the adjusting bolt as described in Step 6 until the adjacent tip is visible.

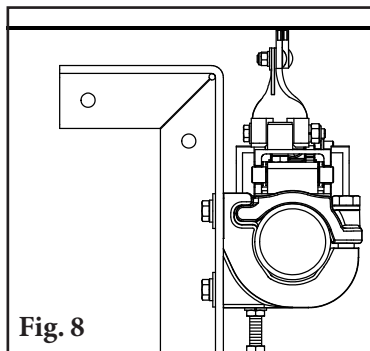

Test run the cleaner and inspect its performance.

If vibration occurs or more cleaning efficiency is desired, increase the tip tension by making a 1/4 turn adjustment on each adjusting bolt.

Section 4.2 - Installation Instructions - Dual Cartridge

R-Type® Enhanced Service Advantage Cartridge Secondary Belt Cleaner

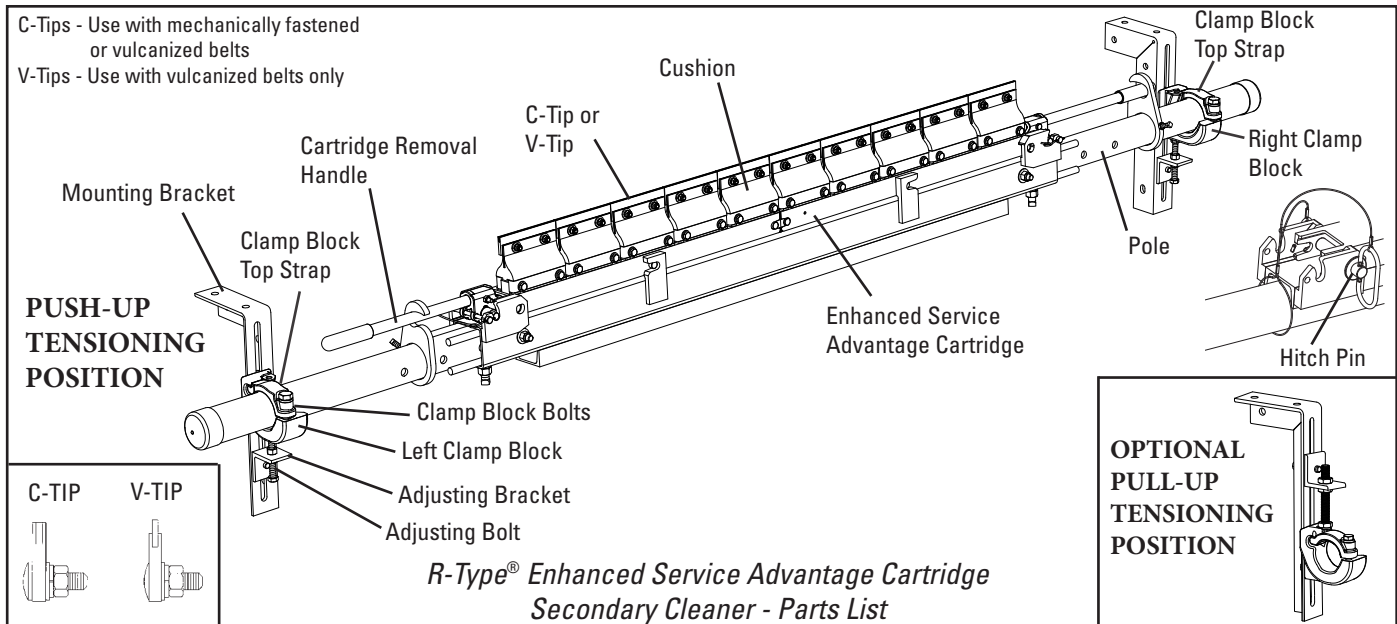

Physically lock out and tag the conveyor at the power source before you begin cleaner installation.

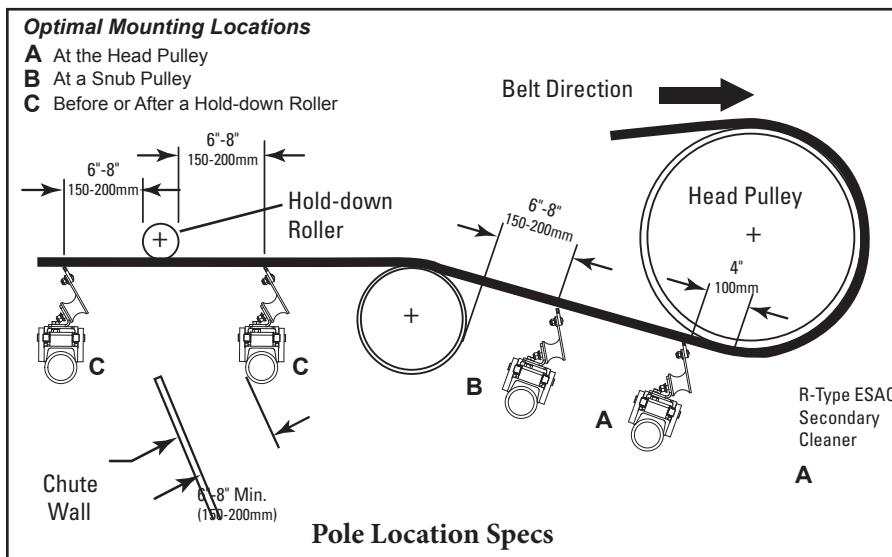

Clearance Requirements for Installation

Vertical	Horizontal
11-3/4" (298mm)	4-1/2" (114mm)

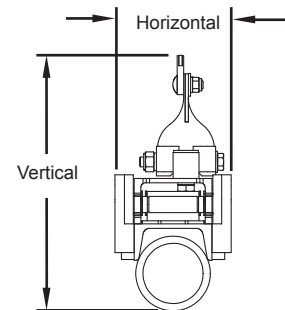

BEFORE YOU BEGIN:

- **PHYSICALLY LOCK OUT AND TAG THE CONVEYOR AT THE POWER SOURCE.**
- Double check the tip style needed for your application:
C-Tip - for mechanically spliced and vulcanized belts.
V-Tip - for vulcanized belts only.
- For chute mounting it may be necessary to cut an access hole to allow for installation and inspections. (See dimensions in STEP 2.)
- Follow all safety precautions when using a cutting torch.
- If welding, protect all fastener threads from weld spatter.
- For cleaner clearance requirements see chart above.

TOOLS NEEDED:

- TAPE MEASURE
- 3/4" (19mm) WRENCH
- Two 1/2" (13mm) WRENCHES
- RATCHET WITH 3/4" (19mm) SOCKET
- Two 6" C-CLAMPS (for temporary positioning of mounting brackets)
- CUTTING TORCH AND/OR WELDER
- MARKING PEN

Section 4.2 - Installation Instructions - Dual Cartridge

1. Install mounting brackets. Determine the correct clamp block (left or right) and bracket needed for each side of the conveyor. The top strap should be offset away from the belt (you should be able to see the notch for the top strap from the outside of the conveyor (Fig. 1a).

For chute mounting: For a chute installation a belt location line must first be established. Draw a line on the chute replicating this location. If head pulley and snub pulley are close, it may be necessary to assume an approximate belt line between the two. In the determined location draw a line perpendicular to the belt line. Make a mark on this line 11-3/4" (298mm) below belt location line (Fig. 1b). Locate a mounting bracket along this line allowing the centerline of the clamp block to align with this 11-3/4" (298mm) mark (Fig. 1c). To move the clamp blocks, if necessary, loosen the clamp block lock bolts and the adjusting bracket lock bolt and move the clamp block to a position where the center of the hole is 11-3/4" (298mm) below the bottom of the belt. Bolt or weld mounting bracket in place. Repeat this step on the opposite side. On one side an access hole may be required (Fig. 1d). **NOTE:** The brackets must be aligned perpendicular to the belt.

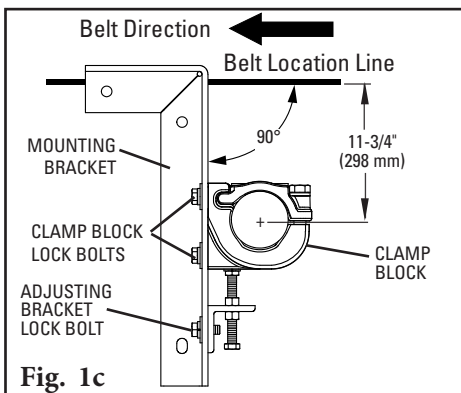
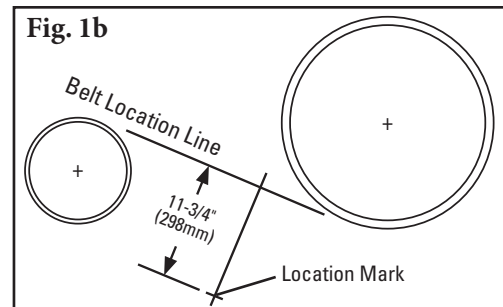
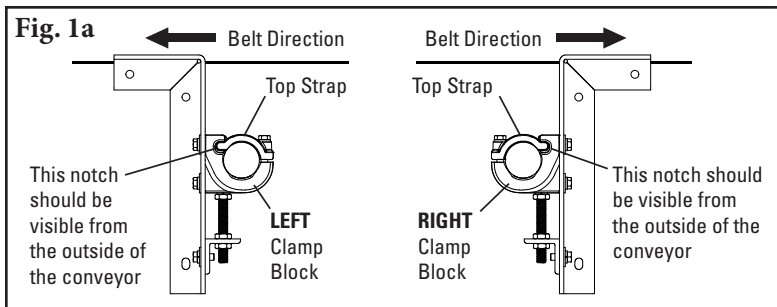

For structure mounting: In most applications the standard mounting brackets will have adequate room to fit on the structure with no cutting. Clamp the mounting bracket into position (use 6" clamps) to align the center of the block with a point 11-3/4" (298mm) below the belt (Fig. 1e). To move the clamp blocks, if necessary, loosen the clamp block lock bolts and the adjusting bracket lock bolt and move the clamp block to a position where the center of the hole is 11-3/4" (298mm) below the bottom of the belt. The bracket can now be bolted or welded in place. Locate and install bracket on the opposite side of belt in alignment with the first bracket. **NOTE:** The brackets must be aligned perpendicular to the belt.

2. Choose the tensioner position. The tensioner is shipped mounted in the push-up position. Depending upon the space constraints of the installation, the tensioner can be optionally mounted in a pull-up position. To do this, loosen the threaded rod lock nut, unscrew the threaded rod and remove adjusting bracket lock bolt. Then move the adjusting bracket and threaded rod to the top of the clamp blocks (Fig. 2) and tighten threaded rod lock nut.

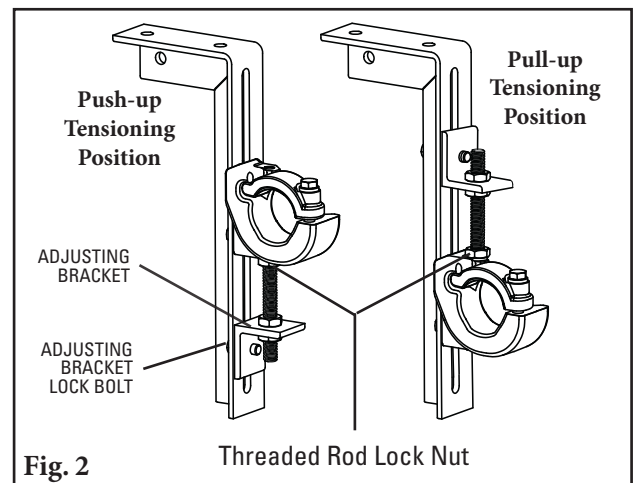
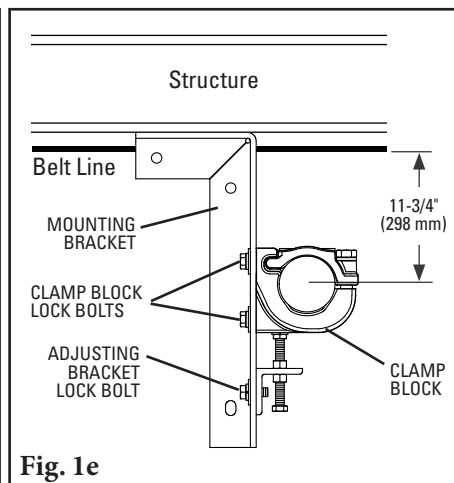
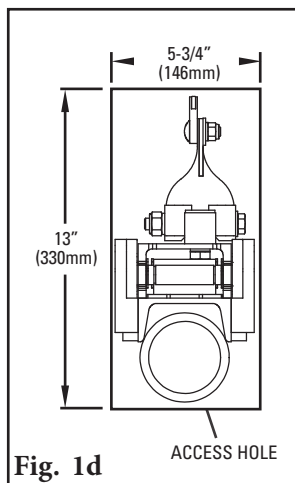

Section 4.2 - Installation Instructions - Dual Cartridge

3. Install the pole.

Remove the cartridge from the pole. Remove the clamp block top strap on the access side of the conveyor, and on the opposite side, loosen the clamp block bolt enough to allow the pole to slide freely through (Fig. 3). Slide the pole across the belt, through the loosened clamp block on opposite side, and locate near end of pole into bottom section of clamp block. Replace the top strap over the pole and reinstall the clamp block bolt finger tight.

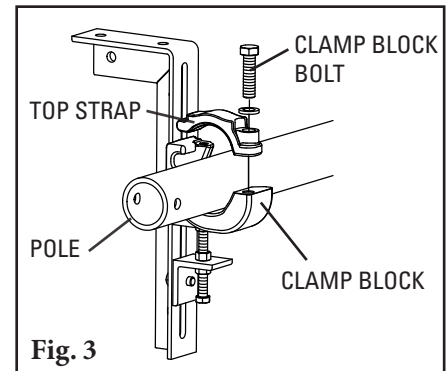

4. Different Cartridge Installation Methods.

Option A: Handle always on cartridge.

1. Slide the handle into the already installed knuckle, then tighten with supplied bolt/nut hardware.
2. Slide the cartridge onto the pole and lock down the knuckle onto the pole.
3. Slide the lock plate onto the pole, over the handle, then lock with the set screw.
4. Repeat for other side.

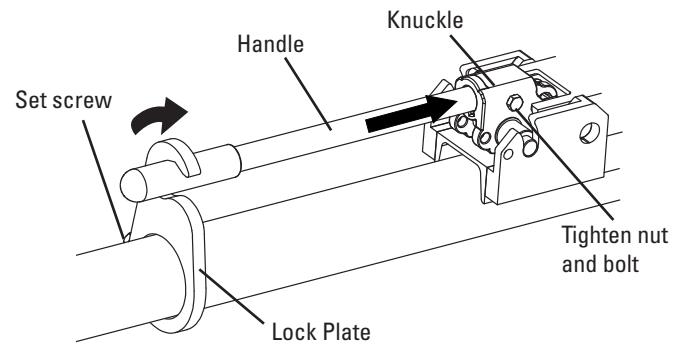

Option B: Handle stored inside pole.

1. Set the cartridge onto the pole, then slide the handle into the already installed knuckle.
2. Lock down the knuckle onto the pole, then remove handle and place into open pole end.
3. Using the lock pins provided, lock the knuckle and the handle in place.
4. Repeat for other side.

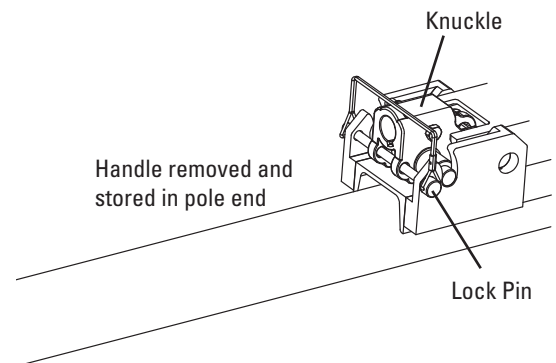

Option C: Hitch pin only.

1. To remove the knuckle assembly from the cartridge, flip cartridge upside down and use two 1/2" (13mm) wrenches to unlock knuckle pivot pins, then remove knuckle assy.
2. Set the cartridge onto the pole.
3. Use rubber mallet (to prevent damage to the cartridge) to lock into place.
4. Using the hitch pin provided, lock the cartridge in place.
5. Repeat for other side.

Use 2 wrenches to loosen pivot pins, then remove knuckle assy

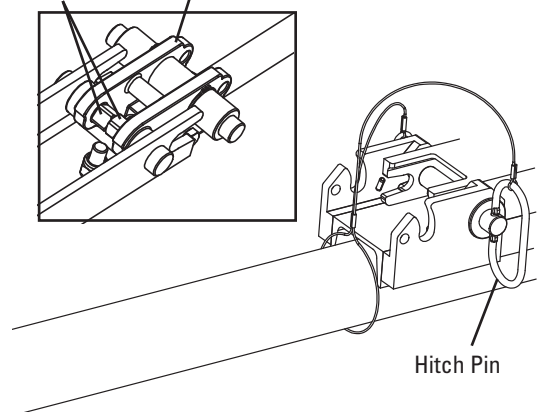

Section 4.2 - Installation Instructions - Dual Cartridge

5. Center the tips on the belt.

Position the pole so the tips are centered on the belt and snug the clamp block bolts on both sides. Do not fully tighten.

6. Set the tip angle.

With angle gauge provided, rotate the tips to the preset angle (Fig. 6) and lock the pole in place by tightening the clamp block bolts equally.

NOTE: Make sure there is NO tip-to-belt contact while making this alignment. If contact occurs, lower the pole by loosening the clamp block lock bolts and raising the top adjusting bolt jam nut (Fig. 6). When the tips are not touching the belt, repeat this step.

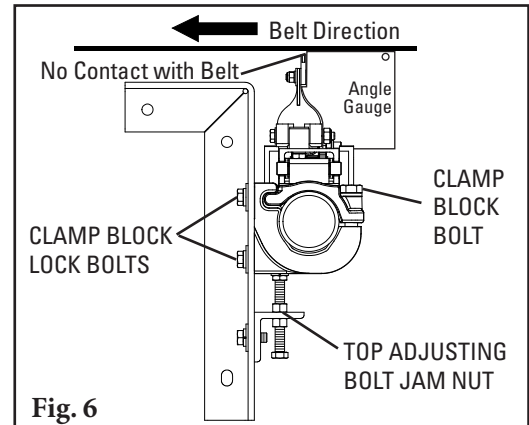

7. Set the tip tension.

With all clamp block lock bolts slightly loosened, back down the bottom adjusting bolt jam nut 4-5 turns on both sides (Fig. 7). Turn the top adjusting bolt jam nuts down until light contact is made between the tips and belt across the entire width of the cleaner. Give an additional 1 full turn to both top adjusting bolt jam nuts and tighten both bottom adjusting bolt jam nuts. Tighten all clamp block lock bolts. Double check that all bolts and nuts on the cleaner are tight.

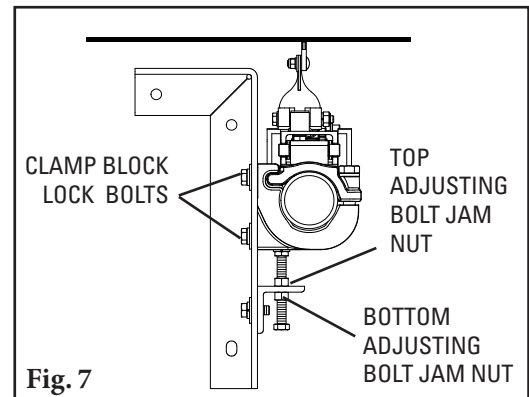

8. Check the tip tension.

Pull back on the outside tip until the tip-to-belt contact is broken and release. If the cleaner is correctly tensioned the complete blade of the adjacent tip will be visible (Fig. 8). If not, add (or reduce) tension by making 1/4 turn adjustments on the adjusting bolt as described in Step 6 until the adjacent tip is visible.

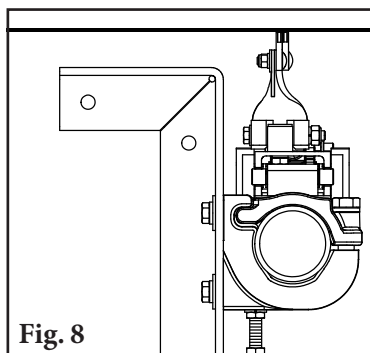

Test run the cleaner and inspect its performance.

If vibration occurs or more cleaning efficiency is desired, increase the tip tension by making a 1/4 turn adjustment on each adjusting bolt.

Section 4.3 - Cartridge Replacement Instructions

R-Type® Enhanced Service Advantage Cartridge Secondary Belt Cleaner

Physically lock out and tag the conveyor at the power source before you begin cleaner installation.

1. Release the tip tension.

With all clamp block lock bolts slightly loosened, turn the top adjusting bolt jam nuts until contact is broken between the tips and belt across the entire width of the cleaner and there is enough clearance to remove the cartridge (approx. 1").

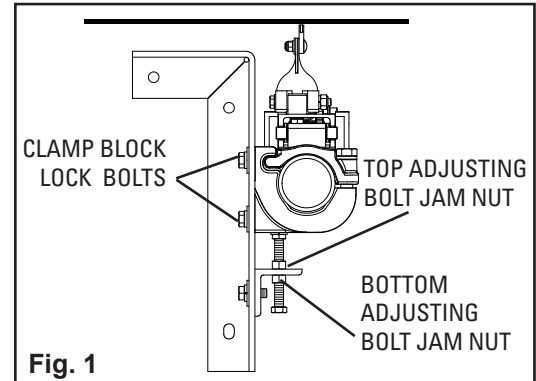

2. Different Cartridge Removal Methods.

Option A: Handle always on cartridge.

1. Loosen the lock plate set screw and disengage lock plate from handle.
2. Lift the handle to unlock the knuckle and cartridge, then pull cartridge out.
3. If using dual cartridge cleaner, repeat for other side.

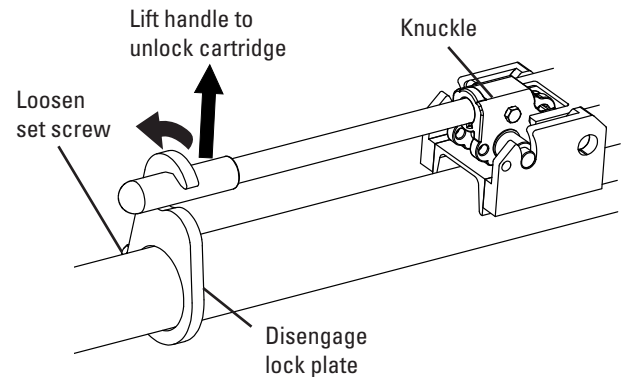

Option B: Handle stored inside pole.

1. Remove lock pins holding handle and knuckle in place.
2. Slide the handle into the knuckle and twist to lock.
3. Lift the handle to unlock the knuckle and cartridge, then pull cartridge out.
4. If using dual cartridge cleaner, repeat for other side.

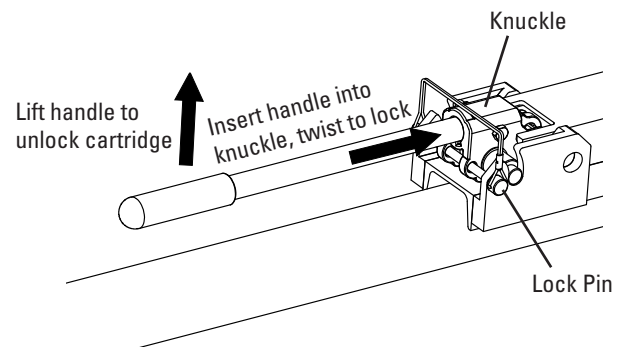

Option C: Hitch pin only.

1. Remove the hitch pin, then pull the cartridge out. Please note this method may require full access to the cleaner to loosen the cartridge.
2. If using dual cartridge cleaner, repeat for other side.

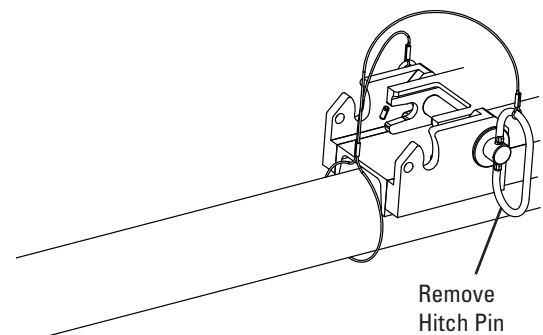

3. Clean off pole. Remove any debris that has built up on the pole.

Section 4.3 - Cartridge Replacement Instructions

4. **Replace the worn tips.** NOTE: If using a dual cartridge cleaner, please use the provided Cartridge Tip Alignment Tool to ensure the tips on both cartridges are located at the same height. It is recommended to use a second cartridge with new tips and cushions already installed for a quick change-out. However, new cleaner tips can be installed on the pulled cartridge on-site if needed.

Single Cartridge:

1. Remove all tips with hardware from the used cartridge.
2. Install all new tips and hardware without fully tightening.
3. Tighten one of the tips on one end of the cartridge.
4. Visually align all others while tightening remaining tips, ensuring a flat profile across all tips. Check with a straightedge. When finished, all tips should move freely without catching on the next tip and have no gaps larger than .030" (approximate thickness of a credit card).

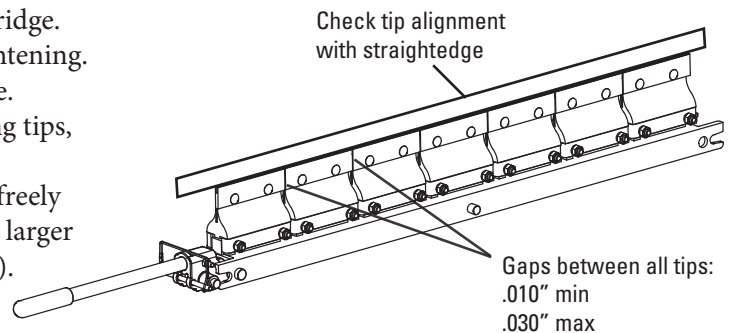

Dual Cartridge:

1. Remove all tips with hardware from the used cartridges.
2. Install all new tips and hardware without fully tightening.
3. On one cartridge, place the Cartridge Tip Alignment Tool on the end with the notch and alignment holes. Using those alignment holes, tighten the tool to the cartridge with wing nut (Fig. 1).
4. Set the tip height gauge on the Cartridge Tip Alignment Tool so that the loosely installed tip can push up into the corner of the tool (Fig. 2).
5. Tighten the first tip while holding it tight to the Cartridge Tip Alignment Tool (Fig. 2).
6. Visually align all others while tightening remaining tips, ensuring a flat profile across all tips. Check with a straightedge. When finished, all tips should move freely without catching on the next tip and have no gaps larger than .030" (approximate thickness of a credit card).
7. Repeat Steps 3, 5 and 6 for second cartridge, making sure to keep the tip height gauge locked in place so that both cartridges will be aligned when assembled to the pole.

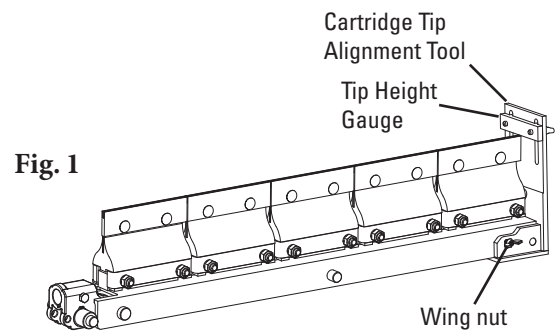

Fig. 1

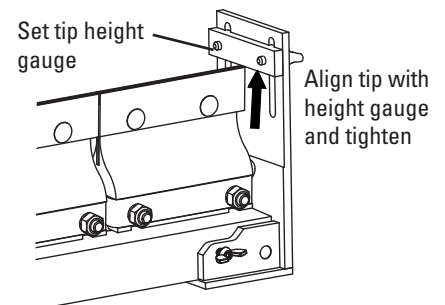

Fig. 2

DO NOT RESET TIP HEIGHT GAUGE WHEN SWITCHING TO SECOND CARTRIDGE

Section 4.3 - Cartridge Replacement Instructions

5. Insert the reconditioned or replacement cartridge.

Option A: Handle always on cartridge.

1. Slide the cartridge onto the pole and lock down the knuckle onto the pole.
2. Slide the lock plate onto the pole, over the handle, then lock with the set screw.
3. If using dual cartridge, repeat for other side.

Option B: Handle stored inside pole.

1. Set the cartridge onto the pole, then slide the handle into the already installed knuckle.
2. Lock down the knuckle onto the pole, then remove handle and place into open pole end.
3. Using the lock pins provided, lock the knuckle and the handle in place.
4. If using dual cartridge, repeat for other side.

Option C: Hitch pin only.

1. Set the cartridge onto the pole.
2. Use hammer and buffer material (to prevent damage to the cartridge) to lock into place.
3. Using the hitch pin provided, lock the cartridge in place.
4. If using dual cartridge, repeat for other side.

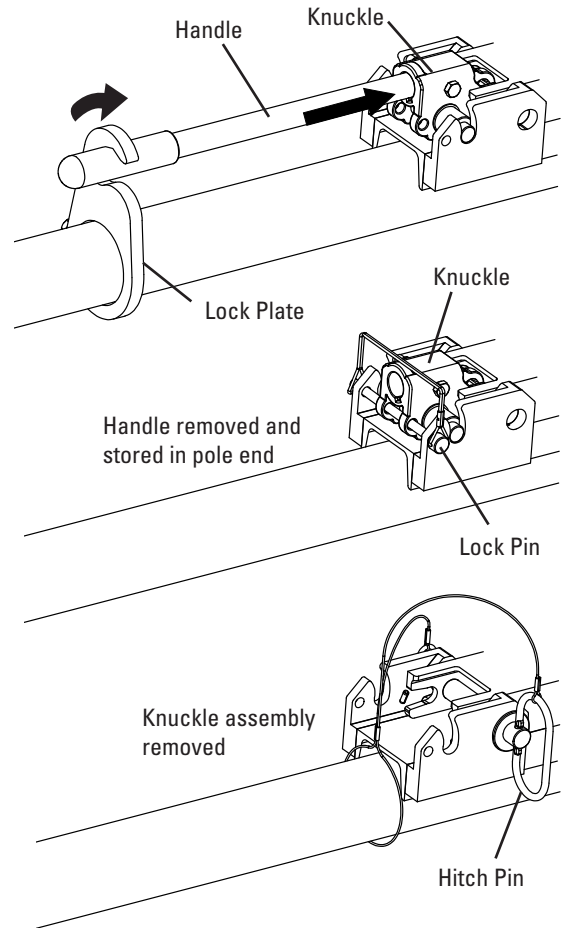

Section 4.3 - Cartridge Replacement Instructions

5. Set the tip tension.

With all clamp block lock bolts slightly loosened, back down the bottom adjusting bolt jam nut 4-5 turns on both sides (Fig. 5). Turn the top adjusting bolt jam nuts down until light contact is made between the tips and belt across the entire width of the cleaner. Give an additional 1 full turn to both top adjusting bolt jam nuts and tighten both bottom adjusting bolt jam nuts. Tighten all clamp block lock bolts. Double check that all bolts and nuts on the cleaner are tight.

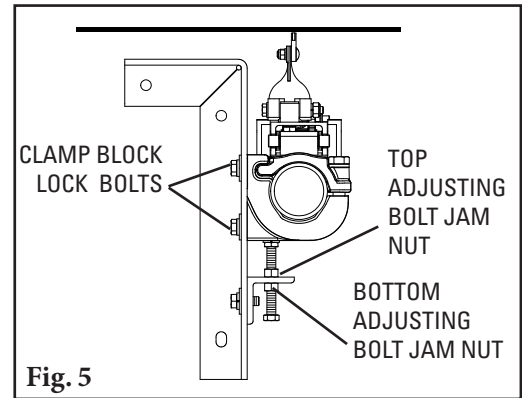

6. Check the tip tension.

Pull back on the outside tip until the tip-to-belt contact is broken and release. If the cleaner is correctly tensioned the complete blade of the adjacent tip will be visible (Fig. 6). If not, add (or reduce) tension by making 1/4 turn adjustments on the adjusting bolt as described in Step 6 until the adjacent tip is visible.

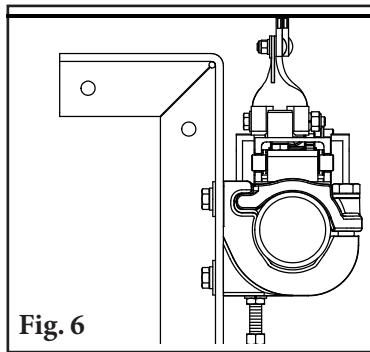

Test run the cleaner and inspect its performance.

If vibration occurs or more cleaning efficiency is desired, increase the tip tension by making a 1/4 turn adjustment on each adjusting bolt.

Section 5 - Pre-Operation Checklist and Testing

5.1 Pre-Op Checklist

- Recheck that all fasteners are tightened properly
- Add pole caps
- Apply all supplied labels to the cleaner
- Check the blade location on the belt
- Be sure that all installation materials and tools have been removed from the belt and the conveyor area

5.2 Test Run the Conveyor

- Run the conveyor for at least 15 minutes and inspect the cleaning performance
- Check the tensioner spring for recommended length (proper tensioning)
- Make adjustments as necessary

NOTE: Observing the cleaner when it is running and performing properly will help to detect problems or when adjustments are needed later.

Section 6 - Maintenance

Flexco belt cleaners are designed to operate with minimum maintenance. However, to maintain superior performance some service is required. When the cleaner is installed a regular maintenance program should be set up. This program will ensure that the cleaner operates at optimal efficiency and problems can be identified and fixed before the cleaner stops working.

All safety procedures for inspection of equipment (stationary or operating) must be observed. The R-Type ESAC Belt Cleaner operates at the discharge end of the conveyor and is in direct contact with the moving belt. Only visual observations can be made while the belt is running. Service tasks can be done only with the conveyor stopped and by observing the correct lockout/tagout procedures.

6.1 New Installation Inspection

After the new cleaner has run for a few days a visual inspection should be made to ensure the cleaner is performing properly. Make adjustments as needed.

6.2 Routine Visual Inspection (every 2-4 weeks)

A visual inspection of the cleaner and belt should look for:

- If adjusting brackets are set correctly for optimal tensioning
- If belt looks clean or if there are areas that are dirty
- If blade is worn out and needs to be replaced
- If there is damage to the blade or other cleaner components
- If fugitive material is built up on cleaner or in the transfer area
- If there is cover damage to the belt
- If there is vibration or bouncing of the cleaner on the belt
- If a snub pulley is used, a check should be made for material buildup on the pulley
- Significant signs of carryback

If any of the above conditions exist, a determination should be made on when the conveyor can be stopped for cleaner maintenance.

6.3 Routine Physical Inspection (every 6-8 weeks)

When the conveyor is not in operation and properly locked and tagged out, a physical inspection of the cleaner to perform the following tasks:

- Clean material buildup off of the cleaner blade and pole
- Closely inspect the blade for wear and any damage. Replace if needed.
- Ensure full blade to belt contact
- Inspect the cleaner pole for damage
- Inspect all fasteners for tightness and wear. Tighten or replace as needed.
- Replace any worn or damaged components
- Check the tension of the cleaner blade to the belt. Adjust the tension if necessary using the steps on Page 15.
- When maintenance tasks are completed, test run the conveyor to ensure the cleaner is performing properly

Section 6 - Maintenance

6.4 Maintenance Log

Conveyor Name/No. _____

Date: _____ Work done by: _____ Service Quote # _____

Activity: _____

Date: _____ Work done by: _____ Service Quote # _____

Activity: _____

Date: _____ Work done by: _____ Service Quote # _____

Activity: _____

Date: _____ Work done by: _____ Service Quote # _____

Activity: _____

Date: _____ Work done by: _____ Service Quote # _____

Activity: _____

Date: _____ Work done by: _____ Service Quote # _____

Activity: _____

Date: _____ Work done by: _____ Service Quote # _____

Activity: _____

Section 6 - Maintenance

6.5 Cleaner Maintenance Checklist

Belt Cleaner: _____ Serial Number: _____

Beltline Information:

Beltline Number: _____ Belt Condition: _____

Belt Width: 24" 30" 36" 42" 48" 54" 60" 72" 84" 96" 120"
(600mm) (750mm) (900mm) (1050mm) (1200mm) (1350mm) (1500mm) (1800mm) (2100mm) (2400mm) (3000mm)

Belt Speed: _____ fpm Belt Thickness: _____

Belt Splice _____ Condition of Splice _____ Number of splices _____ Skived Unskived

Material conveyed _____

Days per week run _____ Hours per day run _____

Blade Life:

Date blades installed: _____ Date blades inspected: _____ Estimated blade life: _____

Are blades making complete contact with belt? Yes No

Blade wear: LEFT _____ MIDDLE _____ RIGHT _____

Blade condition: Good Grooved Smiled Not contacting belt Damaged

Was Cleaner Adjusted: Yes No

Pole Condition: Good Bent Worn

Lagging: Slide lag Ceramic Rubber Other None

Condition of lagging: Good Bad Other _____

Cleaner's Overall Performance: (Rate the following 1 - 5, 1 = very poor - 5 = very good)

Appearance: Comments: _____

Location: Comments: _____

Maintenance: Comments: _____

Performance: Comments: _____

Other Comments: _____



Section 7 - Troubleshooting

Problem	Possible Cause	Possible Solutions
Vibration	Cleaner secure bolts not set	Ensure all locking nuts are tight (Loctite)
	Cleaner not set up correctly	Ensure cleaner set up properly (check tip angle with gauge)
	Belt tension too high	Ensure cleaner can conform to belt, or replace with alternate Flexco secondary cleaner
	Belt flap	Introduce hold-down roller to flatten belt
	Cleaner over-tensioned	Ensure cleaner is correctly tensioned
	Cleaner under-tensioned	Ensure cleaner is correctly tensioned
Material buildup on cleaner	Cleaner not set up correctly	Ensure cleaner set up properly
	Buildup on chute	Ensure cleaner is not located too close to back of chute, allowing buildup
	Cleaner being overburdened	Introduce Flexco precleaner
	Excessive sticky material	Frequently clean unit of buildup
Damaged belt cover	Cleaner over-tensioned	Ensure cleaner is correctly tensioned
	Cleaner blade damage	Check blade for wear, damage and chips, replace where necessary
	Attack angle not correct	Ensure cleaner set up properly (check tip angle with gauge)
	Material buildup in chute	Frequently clean unit of buildup
Cleaner not conforming to belt	Cleaner not set up correctly	Ensure cleaner set up properly (check tip angle with gauge)
	Belt tension too high	Ensure cleaner can conform to belt (introduce hold-down roller), or replace with alternate Flexco secondary cleaner
	Belt flap	Introduce hold-down roller to flatten belt
	Cleaner cannot conform	Ensure cleaner can conform to belt (introduce hold-down roller), or replace with alternate Flexco secondary cleaner
Material passing cleaner	Cleaner not set up correctly	Ensure cleaner set up properly (check tip angle with gauge)
	Cleaner tension too low	Ensure cleaner is correctly tensioned
	Cleaner blades worn/damaged	Check blades for wear, damage and chips, replace where necessary
	Cleaner being overburdened	Introduce Flexco precleaner
	Belt flap	Introduce hold-down roller to flatten belt
	Belt worn or grooved	Introduce water spray pole
	Cleaner cannot conform	Ensure cleaner can conform to belt (introduce hold-down roller), or replace with alternate Flexco secondary cleaner
Damage to mechanical fastener	Incorrect cleaner blade selection	Change blade type to accommodate fastener style (C-Tip or V-Tip)
	Belt not skived correctly	Spot and redo splice correctly, lowering the profile flush or below belt surface
	Blade angle incorrect	Reset with gauge
Missing material in belt center only	Cupped Belt	Install hold-down roller and reset blade angle with gauge
	Cleaner blade worn/damaged	Check blade for wear, damage and chips, replace where necessary
Missing material on outer edges only	Cupped Belt	Install hold-down roller and reset blade angle with gauge
	Cleaner blade worn/damaged	Check blade for wear, damage and chips, replace where necessary

Section 8 - Specs and CAD Drawings

Pole Length Specifications*

VERSION	CLEANER SIZE		BLADE WIDTH		POLE LENGTH		MAXIMUM CONVEYOR SPAN	
	in.	mm	in.	mm	in.	mm	in.	mm
Single	24	600	24	600	78	1950	66	1650
	30	750	30	750	84	2100	72	1800
	36	900	36	900	90	2250	78	1950
	42	1050	42	1050	96	2400	84	2100
	48	1200	48	1200	102	2550	90	2250
	54	1350	54	1350	108	2700	96	2400
	60	1500	60	1500	114	2850	102	2550
Dual	72	1800	72	1800	126	3150	114	2850
	60	1500	60	1500	120	3000	108	2700
	72	1800	72	1800	132	3300	120	3000
	84	2100	84	2100	144	3600	132	3300
	96	2400	96	2400	156	3900	144	3600
	120	3000	120	3000	180	4500	168	4200

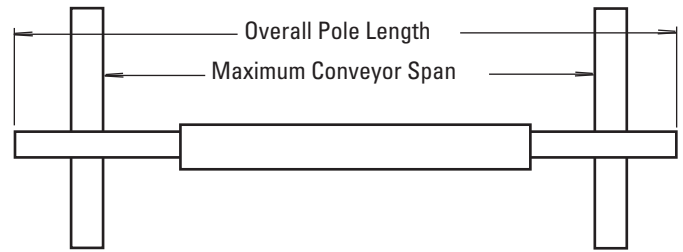

*For special extra long pole length requirements a Pole Extender Kit (#76024) is available that provides 30" (750mm) of extended pole length. Pole Diameter - 2-7/8" (73mm)

Clearance Guidelines for Installation

VERSION	HORIZONTAL CLEARANCE REQUIRED		VERTICAL CLEARANCE REQUIRED	
	in.	mm	in.	mm
Single	4-1/2	114	10	254
Dual	4-1/2	114	11-3/4	298

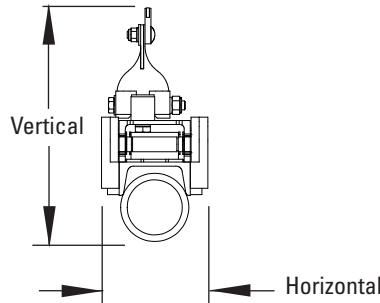

Aluminum Content

ALUMINUM ALLOY TYPE	PERCENT	
	Mg Magnesium	Ti Titanium
6061	1.0%	0.0%

Specifications:

- Maximum Belt Speed 1000 FPM (5M/sec)
- Temperature Rating -30°F to 180°F (-35°C to 82°C)
- Usable Blade Wear Length 3/8" (9mm)
- Blade Materials C-Tip: Impact Resistant Tungsten Carbide (works with mechanical fasteners)
V-Tip: Long Life Tungsten Carbide (for vulcanized belts only)
- Available for Belt Widths 24" to 120" (600 to 3000 mm). Other sizes available upon request.

Patent Pending

Section 8 - Specs and CAD Drawings

8.2 CAD Drawing - R-Type ESAC with C-Tips - Single Cartridge

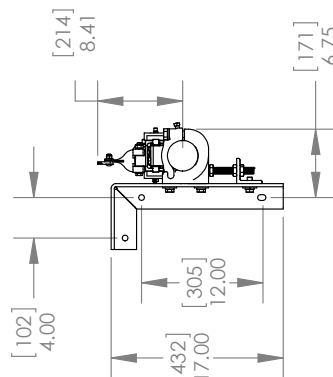
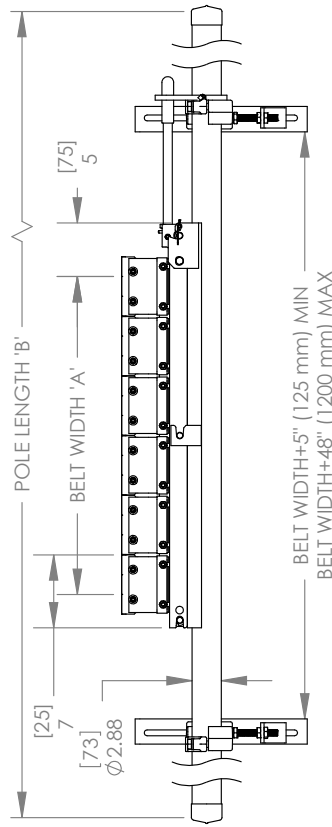
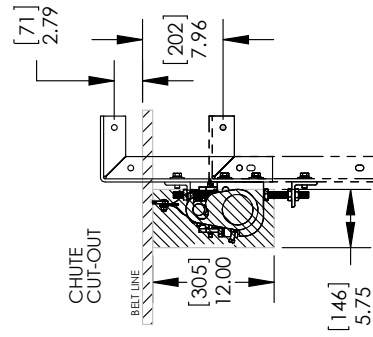
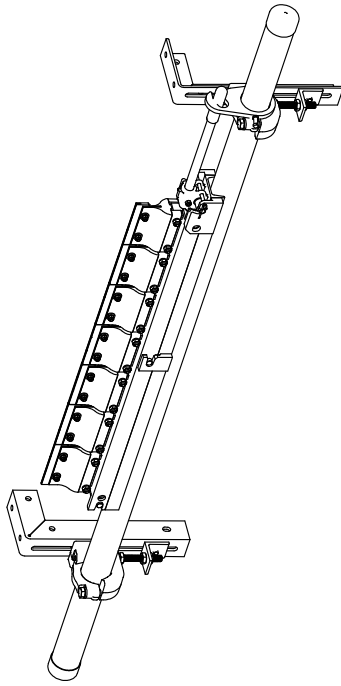

SPECIFICATIONS		SAC RC CLEANER		ITEM NUMBER 1 SA CARTRIDGE POLE		ITEM NUMBER 2 SA CARTRIDGE		ITEM NUMBER 3 SAC R ADAPTER PLATE	
BELT WIDTH 'A' (in)	BELT WIDTH 'A' (mm)	ORDER NUMBER	ITEM CODE	ORDER NUMBER	ITEM CODE	ORDER NUMBER	ITEM CODE	ORDER NUMBER	ITEM CODE
24	600	RC24-ESAC	77968	SACPL-24/600	77887	CART-24/600	77900	RCAP-24/600	77921
30	700	RC30-ESAC	77969	SACPL-30/750	77888	CART-30/750	77901	RCAP-30/750	77922
36	900	RC36-ESAC	77970	SACPL-36/900	77889	CART-36/900	77902	RCAP-36/900	77923
42	1050	RC42-ESAC	77971	SACPL-42/1050	77890	CART-42/1050	77903	RCAP-42/1050	77924
48	1200	RC48-ESAC	77972	SACPL-48/1200	77891	CART-48/1200	77904	RCAP-48/1200	77925
54	1350	RC54-ESAC	77973	SACPL-54/1350	77892	CART-54/1350	77905	RCAP-54/1350	77926
60	1500	RC60-ESAC	77974	SACPL-60/1500	77893	CART-60/1500	77906	RCAP-60/1500	77927
72	1800	RC72-ESAC	77975	SACPL-72/1800	77894	CART-72/1800	77907	RCAP-72/1800	77928

Section 8 - Specs and CAD Drawings

8.2 CAD Drawing - R-Type ESAC with V-Tips - Single Cartridge

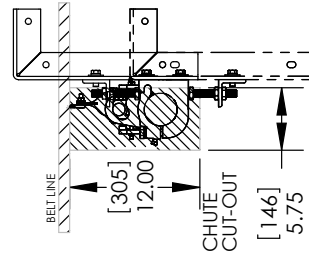
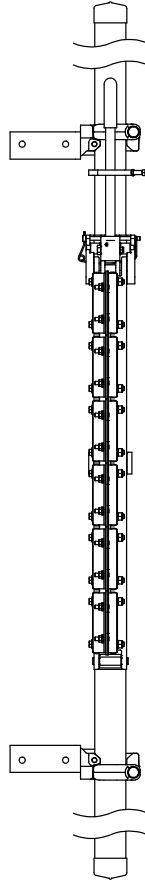
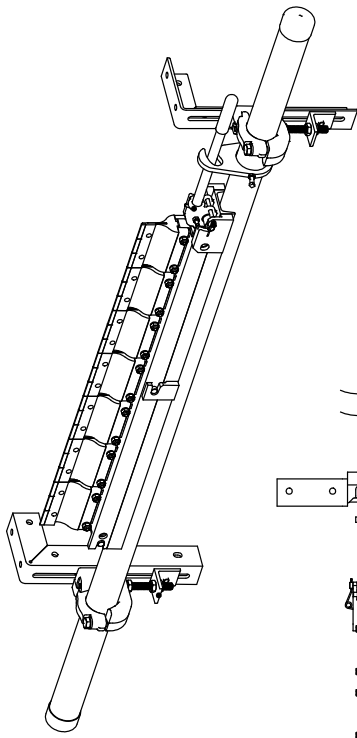

SPECIFICATIONS		SAC RV CLEANER		SA CARTRIDGE POLE		SA CARTRIDGE		SAC R ADAPTER PLATE	
BELT WIDTH 'A'	POLE LENGTH 'B'	ORDER NUMBER	ITEM CODE	ORDER NUMBER	ITEM CODE	ORDER NUMBER	ITEM CODE	ORDER NUMBER	ITEM CODE
24	600	RV24-ESAC	77994	SACPL-24/600	77887	CART-24/600	77900	RCAP-24/600	77921
30	700	RV30-ESAC	77995	SACPL-30/750	77888	CART-30/750	77901	RCAP-30/750	77922
36	900	RV36-ESAC	77996	SACPL-36/900	77889	CART-36/900	77902	RCAP-36/900	77923
42	1050	RV42-ESAC	77997	SACPL-42/1050	77890	CART-42/1050	77903	RCAP-42/1050	77924
48	1200	RV48-ESAC	77998	SACPL-48/1200	77891	CART-48/1200	77904	RCAP-48/1200	77925
54	1350	RV54-ESAC	77999	SACPL-54/1350	77892	CART-54/1350	77905	RCAP-54/1350	77926
60	1500	RV60-ESAC	78000	SACPL-60/1500	77893	CART-60/1500	77906	RCAP-60/1500	77927
72	1800	RV72-ESAC	78001	SACPL-72/1800	77894	CART-72/1800	77907	RCAP-72/1800	77928

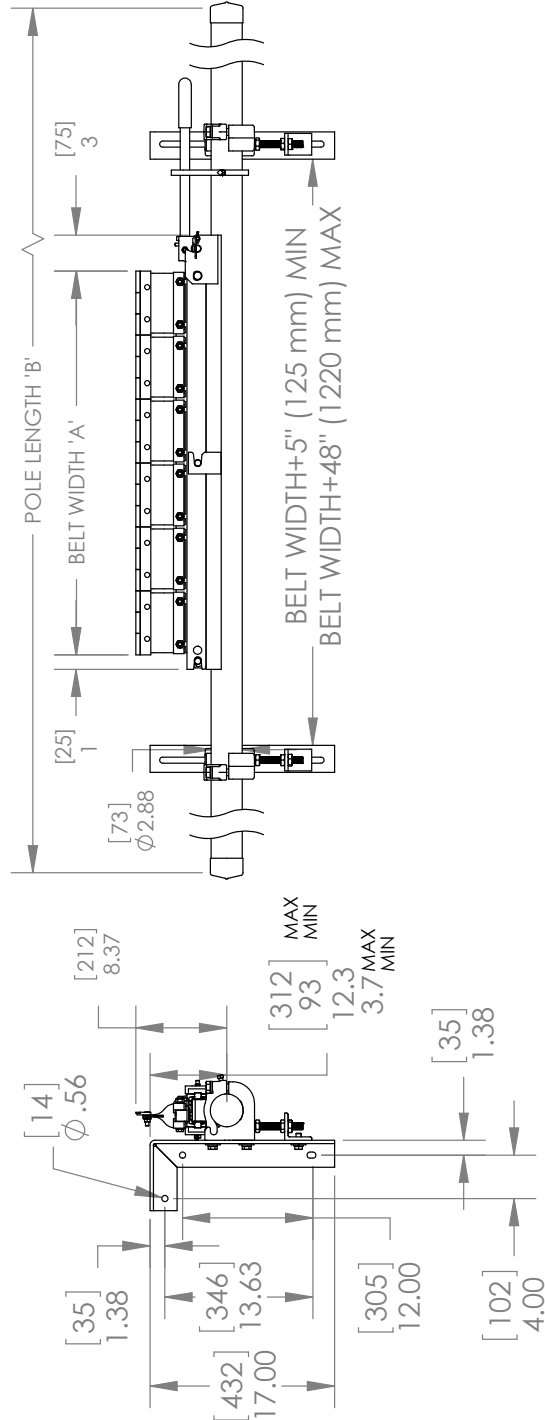

Section 8 - Specs and CAD Drawings

8.2 CAD Drawing - R-Type ESAC with C-Tips - Dual Cartridge

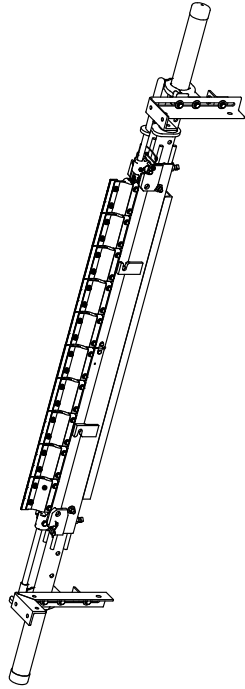

SPECIFICATIONS		SAC R-TYPE C CLEANER		SAC CENTER POLE		SA CARTRIDGE SET		SAC R ADAPTER PLATE	
BELT WIDTH 'A' (in)	MAX POLE LENGTH 'B' (mm)	ORDER NUMBER	ITEM CODE	ORDER NUMBER	ITEM CODE	ORDER NUMBER	ITEM CODE	ORDER NUMBER	ITEM CODE
60	1500	RC-60-2ESAC	77976	SACPL2-60/1500	77895	CART2-60/1500	77908	RCAP-30/750	77922
72	1800	RC72-2ESAC	77977	SACPL2-72/1800	77896	CART2-72/1800	77909	RCAP-36/900	77923
84	2100	RC84-2ESAC	77978	SACPL2-84/2100	77897	CART2-84/2100	77910	RCAP-42/1050	77924
96	2400	RC96-2ESAC	77979	SACPL2-96/2400	77898	CART2-96/2400	77911	RCAP-48/1200	77925
120	3000	RC120-2ESAC	77980	SACPL2-120/3000	77899	CART2-120/3000	77912	RCAP-60/1500	77927

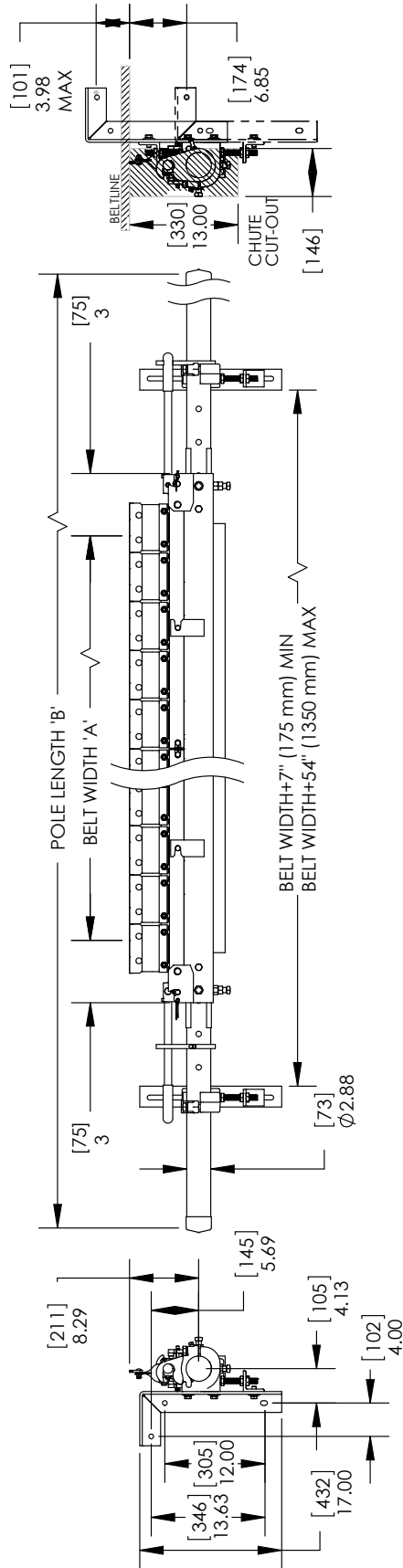
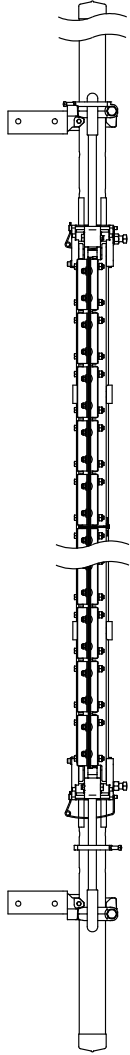

Section 8 - Specs and CAD Drawings

8.2 CAD Drawing - R-Type ESAC with V-Tips - Dual Cartridge

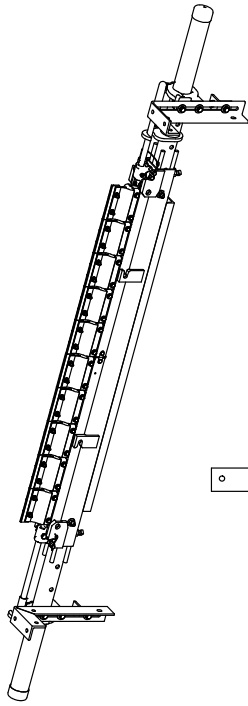

SPECIFICATIONS		SAC R-TYPE V CLEANER		SAC CENTER POLE		SA CARTRIDGE SET		SAC R ADAPTER PLATE	
BELT WIDTH 'A' (in)	MAX POLE LENGTH 'B' (mm)	ORDER NUMBER	ITEM CODE	ORDER NUMBER	ITEM CODE	ORDER NUMBER	ITEM CODE	ORDER NUMBER	ITEM CODE
40	120	RV60-2ESAC	78002	SACPL2-40/1500	77895	CART2-40/1500	77908	RCAP-30/750	77922
72	132	RV72-2ESAC	78003	SACPL-72/1800	77896	CART2-72/1800	77909	RCAP-36/900	77923
84	144	RV84-2ESAC	78004	SACPL-84/2100	77897	CART2-84/2100	77910	RCAP-42/1050	77924
96	156	RV96-2ESAC	78005	SACPL-96/2400	77898	CART2-96/2400	77911	RCAP-48/1200	77925
120	180	RV120-2ESAC	78006	SACPL-120/3000	77899	CART2-120/3000	77912	RCAP-60/1500	77927

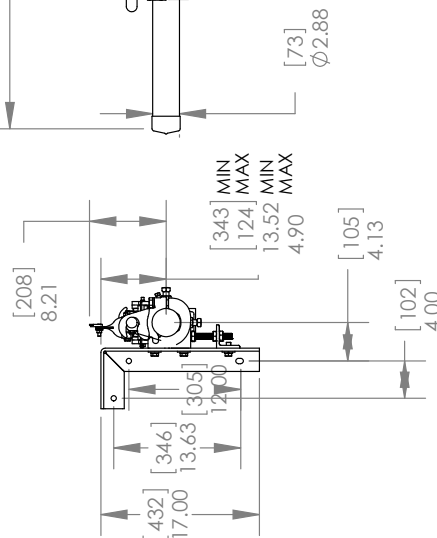
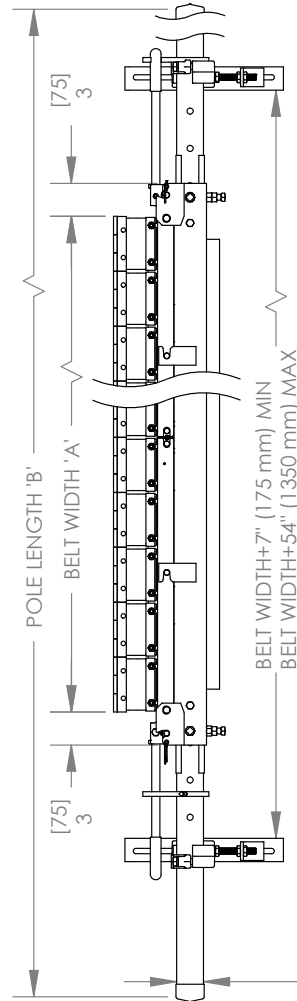
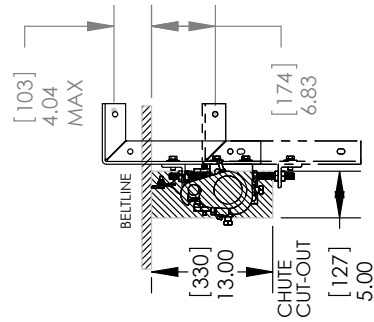
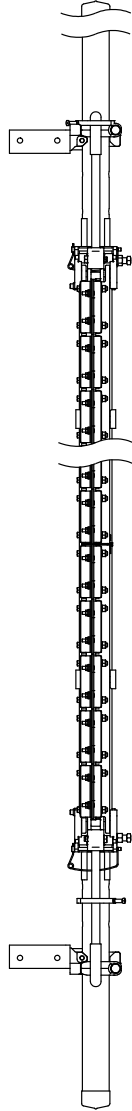

Section 9 - Replacement Parts

9.1 Replacement Parts List - R-Type ESAC Secondary Cleaners

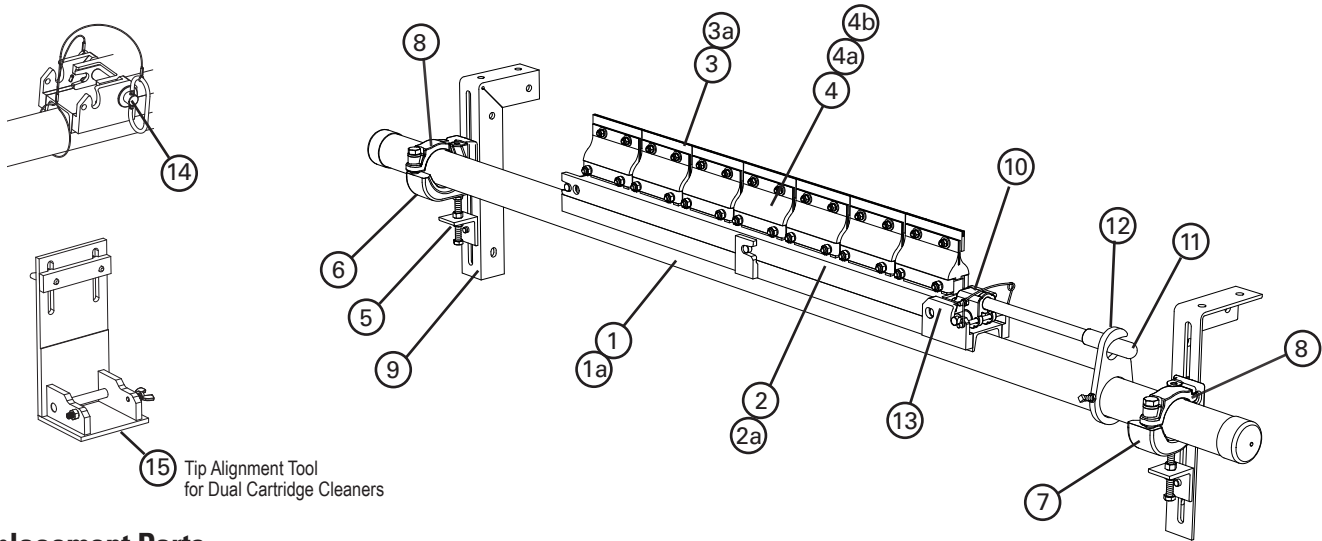

Replacement Parts

REF	DESCRIPTION	ORDERING NUMBER	ITEM CODE	WT. LBS.
1	ESAC Cartridge Pole 24"	SACPL-24/600	77887	65.4
	ESAC Cartridge Pole 30"	SACPL-30/750	77888	71.2
	ESAC Cartridge Pole 36"	SACPL-36/900	77889	77.1
	ESAC Cartridge Pole 42"	SACPL-42/1050	77890	82.9
	ESAC Cartridge Pole 48"	SACPL-48/1200	77891	88.8
	ESAC Cartridge Pole 54"	SACPL-54/1350	77892	94.6
	ESAC Cartridge Pole 60"	SACPL-60/1500	77893	100.5
	ESAC Cartridge Pole 72"	SACPL-72/1800	77894	112.2
	ESAC Cartridge Center Pole 60" (Dual)	SACPL2-60/1500	77895	77.3
	ESAC Cartridge Center Pole 72" (Dual)	SACPL2-72/1800	77896	89.5
	ESAC Cartridge Center Pole 84" (Dual)	SACPL2-84/2100	77897	101.8
	ESAC Cartridge Center Pole 96" (Dual)	SACPL2-96/2400	77898	114.1
	ESAC Cartridge Center Pole 120" (Dual)	SACPL2-120/3000	77899	142.3
	1a	Extender Pole (for use with Dual Cartridge Center Pole)	MHP-EP	76392
2	ESAC Cartridge 24"	CART-24/600	77900	3.5
	ESAC Cartridge 30"	CART-30/750	77901	4.3
	ESAC Cartridge 36"	CART-36/900	77902	5.1
	ESAC Cartridge 42"	CART-42/1050	77903	5.9
	ESAC Cartridge 48"	CART-48/1200	77904	6.7
	ESAC Cartridge 54"	CART-54/1350	77905	7.4
	ESAC Cartridge 60"	CART-60/1500	77906	8.4
	ESAC Cartridge 72"	CART-72/1800	77907	10.0
	ESAC Cartridge 60" (Dual)	CART2-60/1500	77908	8.6
	ESAC Cartridge 72" (Dual)	CART2-72/1800	77909	10.2
	ESAC Cartridge 84" (Dual)	CART2-84/2100	77910	11.7
	ESAC Cartridge 96" (Dual)	CART2-96/2400	77911	13.3
	ESAC Cartridge 120" (Dual)	CART2-120/3000	77912	16.8
	2a	ESAC Cartridge P-Type Adapter Plate 24"	RCAP-24/600	77921
ESAC Cartridge P-Type Adapter Plate 30" §		RCAP-30/750	77922	7.9
ESAC Cartridge P-Type Adapter Plate 36" §		RCAP-36/900	77923	9.4
ESAC Cartridge P-Type Adapter Plate 42" §		RCAP-42/1050	77924	11.1
ESAC Cartridge P-Type Adapter Plate 48" §		RCAP-48/1200	77925	12.6
ESAC Cartridge P-Type Adapter Plate 54"		RCAP-54/1350	77926	14.2
ESAC Cartridge P-Type Adapter Plate 60" §		RCAP-60/1500	77927	15.8
ESAC Cartridge P-Type Adapter Plate 72"		RCAP-72/1800	77928	19.0

§ If using a dual cartridge, please take the cleaner size and divide by two. That dimension is the size of the brackets needed for conversion to a P-Type cleaner.

REF	DESCRIPTION	ORDERING NUMBER	ITEM CODE	WT. LBS.
3	C-Tip*	ICT6	74535	0.7
3a	P V-Tip* (for vulcanized belts only)	PSA150	73156	1.0
4	P2 C-Tip Cushion*	PHA	73626	2.0
4a	P Cushion SS Neoprene* (oil resistant)	PSSC	77045	3.5
4b	P Cushion Neoprene* (oil resistant)	PNC	74984	3.5
5	Adjusting Bracket Kit* (1 ea.)	PAB	75513	1.5
6	HD Pole Clamp Kit Left* (1 ea.) (incl. item 8)	CCKHDL	79225	8.7
7	HD Pole Clamp Kit Right* (1 ea.) (incl. item 8)	CCKHDR	79229	8.7
8	HD Cradle Clamp Top Strap (1 ea.) for use with L or R HD Pole Clamp Kit	CCKHDT	79233	1.7
9	Mounting Bracket Kit (1 Right and 1 Left)	EZS2MBK	75666	13.0
-	HD Cradle Clamp Mounting Kit* (incl. 2 ea. items 5; 1 ea. items 6, 7 & 9)	CCMKHD	78920	36.7
10	ESAC Removal Knuckle	SACRKN	77882	3.2
11	ESAC Removal Handle	SACRH	77883	3.0
12	ESAC Handle Lock Plate	SACRHL	77884	1.7
13	Knuckle Retainer Pin	SACKRP	77885	0.2
14	SAC Hitch Pin	SACHP2	77768	0.9
-	ESAC Removal Kit (includes 1 ea. items 10, 11, 12, 13 & 14)	SACRKT	77886	9.0
15	ESAC Cartridge Tip Alignment Tool (Dual)	SAC2-TIP-TL	77866	2.5

*Hardware Included
Lead Time: 1 working day

Section 10 - Other Flexco Conveyor Products

Flexco provides many conveyor products that help your conveyors to run more efficiently and safely. These components solve typical conveyor problems and improve productivity. Here is a quick overview on just a few of them:

MMP Precleaner



- Extra cleaning power right on the head pulley
- A 10" (250mm) TuffShear™ blade provides increased blade tension on the belt to peel off abrasive materials
- The unique Visual Tension Check™ ensures optimal blade tensioning and quick, accurate retensioning
- Easy to install and simple to service

DRX Impact Beds



- Exclusive Velocity Reduction Technology™ to better protect the belt
- Slide-Out Service™ gives direct access to all impact bars for change-out
- Impact bar supports for longer bar life
- 4 models to custom fit to the application

MDWS DryWipe Secondary Cleaner



- Wipes the belt dry as final cleaner in system
- Automatic blade tensioning to the belt
- Easy, visual blade tension check
- Simple, one-pin blade replacement

PT Max™ Belt Trainer



- Patented "pivot & tilt" design for superior training action
- Dual sensor rollers on each side to minimize belt damage
- Pivot point guaranteed not to freeze up
- Available for topside and return side belts

Flexco Specialty Belt Cleaners



- "Limited space" cleaners for tight conveyor applications
- High Temp cleaners for severe, high heat applications
- A rubber fingered cleaner for chevron and raised rib belts
- Multiple cleaner styles in stainless steel for corrosive applications

Belt Plows



- A belt cleaner for the tail pulley
- Exclusive blade design quickly spirals debris off the belt
- Economical and easy to service
- Available in vee or diagonal models

The Flexco Vision

To become the leader in maximising
belt conveyor productivity for our customers worldwide
through superior service and innovation.



2525 Wisconsin Avenue • Downers Grove, IL 60515-4200 • USA
Tel: (630) 971-0150 • Fax: (630) 971-1180 • E-mail: info@flexco.com

Visit www.flexco.com for other Flexco locations and products.

©2014 Flexible Steel Lacing Company. 09/14. For reorder: X2379

